

KL-S180

semi-automatic round bottle labeling machine

Operating manual



Zhejiang Kangling Machinery Manufacturing CO.,LTD

A. Overview

1. Scope of application

KL-S180 semi-automatic round bottle labeling machine is an ideal equipment for semi-automatic labeling of round bottle products in daily chemical, food and beverage, medicine, chemical and other light industries.

This machine is suitable for round bottles of various sizes and is suitable for small batch and multi-variety production. This machine can only be used for stand-alone labeling.

For other uses, please consult the manufacturer. The manufacturer is not responsible for any damage caused by non-compliant use. Such risks are solely borne by the user.

Strict compliance with the instruction manual is part of the requirements for the use of this machine.

2. Performance characteristics

This machine has reasonable structure, reliable performance and simple operation. Using photoelectric detection, accurate labeling.

- Adopt advanced labeling mechanism to ensure labeling accuracy.
- Can label a variety of bottles with strong adaptability.
- The label photoeye can identify and compare label backing papers with different light transmittances, and move the photoeye position to make the best adjustments to labels of different lengths to ensure normal labeling and smooth and accurate labeling.
- All mechanisms including frame, shell, traction device, crossbar and fasteners are mostly made of stainless steel and aluminum materials. They are used in a normal working environment to ensure no rust and pollution.
- The system control components all have international standardization certification, and have undergone strict inspection and testing in the factory to ensure the reliability of various functions.

B. Technical parameters

1. Machine parameters

The maximum output of a single non-positioning labeling: ≤ 50 pieces/min
(related to the size of the bottle label)

Labeling bottle outer diameter: $\Phi 20-150$ mm

Power: 50W

Voltage: 110V 60Hz

Operating environment temperature: 5-45°C

Weight: 25Kg

Relative humidity: 15-90%

Dimensions: 800X320X460mm

2. Overriding parameters

Labeling speed: 3-15m/min

Labeling accuracy: ± 0.5 mm (excluding package and label errors)

Minimum length of labeling: 10mm

3. Label parameters

- Label bottom paper adopts Glassine bottom paper (that is, translucent bottom paper or translucent bottom paper)
- The thickness of the label paper is not less than 5 μ m
- The outer diameter of the label roll is $\Phi 300\text{mm}$, and the inner diameter of the label roll core is $\Phi 76\text{mm}$

C. construction and installation

1. Schematic diagram of winding mark

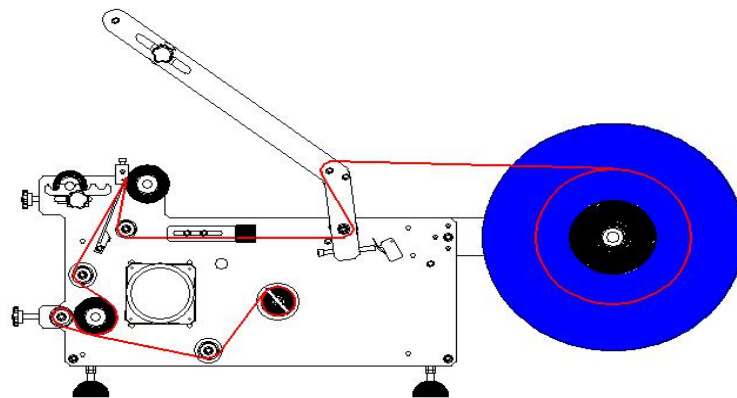

2. Schematic

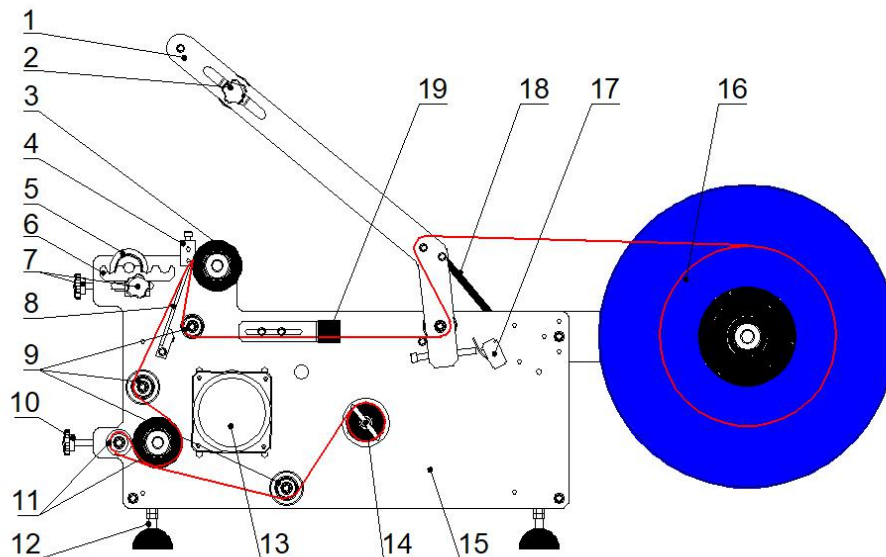

1. Bottle pressure swing arm
2. Bottle pressure roller
3. Over-label roller
4. Positioning rod
5. Bottle supporting roller

6. Bottle supporting bracket
7. Position adjustment handle
8. Stripping plate
9. Guide roller
10. Traction roller locking handle
11. Traction roller
12. Foot base
13. Motor
14. Bottom paper recovery roller
15. Main mounting plate
16. Feed tray device
17. Travel switch
18. Swing arm tension spring
19. Marking sensor

D. adjustments before starting

1. Adjust the bottle support

Loosen the position adjustment handle screws under the left and right brackets of the bottle holding roller (Figure 1-7), adjust and move the bottle holding bracket (Figure 1-6) according to the diameter of the labelled round bottle, so that the bottle is on the bottle holding roller (Figure 1-5) Between the labeling roller (Figure 1-3); the larger the diameter of the bottle, the greater the distance between the two rollers. After adjusting to a suitable position, tighten the handle screw.

2. Adjust the pressure bottle roller

Loosen the handle screws at both ends of the bottle pressing roller (Figure 1-2), and adjust the bottle pressing roller to the proper position so that the bottle pressing roller just presses the bottle when it rotates with the bottle pressing swing arm (Figure 1-1). In the center position, tighten the handle screw after adjustment.

3. Adjust the limit switch to touch the screw

First loosen the touch screw downwards, and then turn the bottle pressing swing arm (Figure 1-1) to make the bottle pressing roller (Figure 1-2) press the labeling round bottle, and slowly move the touch screw to the stroke switch (Figure 1-17) Adjust the direction until the flap against the travel switch makes a switch action sound. After the adjustment is completed, tighten the nut.

4. Adjust the position of the positioning rod

Adjust the positioning rod to the proper position so that the label is affixed to the correct position of the bottle.

5. Adjust the label stripping board

Adjust the stripping plate (Figure 1-8), make the stripping plate as close as possible to the overlaid roller (Figure 1-3), but not in contact with it.

6. Install label roll

As shown in Figure 1, install the entire roll of labels on the feeding tray device (Figure 1-16), with the label side facing up and the bottom paper side down, install the

label paper according to the drawing diagram, and finally lock both sides of the traction roller. The handle screw makes the knurled aluminum wheel press the rubber traction roller to have a certain pressure, and the pressure on both sides is even.

7. Adjust the position of the electric eye

Adjust the left and right positions of the plate metal of the electric eye to adjust the length of the pre-out mark. The length of the label beyond the stripping plate is generally 3-5mm.

8. Clean up before booting

Remove all the sundries on the traction roller, guide roller, stripping plate, label covering roller, bottle holding roller, bottle pressing roller, and chassis, and check whether all screws are tight.

E. Electrical equipment adjustment

1. Power and switch

This model uses AC 220V voltage and a single-phase three-wire three-core power plug. Check the power socket used before use to ensure that the machine is reliably grounded. Plug in the power cord and turn on the power switch.

2. Setting up the standard measuring electric eye

Key operation:

① Press and hold the button for 4 seconds, the red indicator light flashes once, release the button at this time, and the product is in the calculation state. At this time, move the tested label back and forth, and the product automatically records related parameters. After the recording is completed, the red light stops flashing and becomes a steady light.

② Press and hold the button for 4 seconds, the red indicator light flashes once, after keeping the button pressed for 8 seconds, the indicator light flashes again. The output state of the product is switched between normally open and normally closed. Note: This product has been adjusted to normally open output from the factory, and general customers do not need to select this function.

- The red indicator light is the status light;
- The green indicator light is the output signal indicator;

Voltage: DC: 24V

F. Start-up operation workflow

When all the relevant parameters are set and debugged, turn on the power, put the round bottle between the bottle support roller and the labeling roller, the bottom of the bottle is against the positioning rod, and the bottle pressing arm is used to make the bottle pressing roller press the label. Round bottle, at this time, the lower end of the swing arm touches the screw and just touches the travel switch, the travel switch is turned on, and the signal is transmitted to the control module. The control module drives the motor to run. The motor drives the traction roller, the labeling roller, and the bottom paper through the sprocket chain. Recycle the roller, pull the label paper, and peel off the label from the label bottom paper by peeling the label board, and at the same time, the labeling roller drives

the round bottle to rotate together. At this time, the peeled off label is attached to the round bottle. In position, the labeling is completed. The normal labeling work is repeated in this way.

G. Maintenance

The operators of this machine must be trained before they can operate and use the machine. In order to maximize the efficiency of the machine, the user must always pay attention to the operation of the machine during use and should do routine and regular maintenance of the machine. The following is a guide for maintenance.

1. Daily maintenance

Everyday before starting

- It is necessary to check whether there are sundries on the rubber rollers, traction rollers, guide rollers, stripping plates, etc.;
- Observe whether the power supply is normal and whether the power cord is damaged;
- Regularly clean and maintain the machine surface;
- Pay attention to observe whether there are loose screws on the machine, if found, tighten them immediately;

H. Malfunction and solutions

Symptom	Cause	Solution
1. No Label	Wrong position of travel switch	Adjust the position of the travel switch
	Travel switch error	Replace the travel switch
	The traction roller does not press the label tape tightly, and it slips when pulling the label	Tighten the adjusted handle screw
	The power switch is not turned on	Open the power switch
2. Continuous label	The position of the measuring standard electric eye is wrong or the label tape does not pass through the detection position of the electric eye slot	Adjust the position of the electric eye
	Marking electric eye error	Adjust or replace the electric eye
3. Inaccurate labeling axial position	The front and rear position of the positioning rod is not positioned	Lock the positioning rod
	The position of the label on the stripping board is incorrect	Re-adjust the label position
	The bottom of the bottle did not stick to the positioning rod when placing the bottle	Please put the bottle correctly

4. Not labelled	The reserved label is not long enough	Adjust the length of the reserved label
	The surface of the object is not sufficiently sticky with the label or the humidity is too high	Check the surface of the bottle
	The bottle pressing roller does not press the round bottle to be pasted, and the round bottle to be pasted does not rotate	Adjust the bottle gap
5. Wrinkles after label application	Reserved label is too long	Reduce the length of the reserved label
	There is debris on the surface of the round bottle	Clean the surface of the bottle
	Label peeling plate and labeling rubber roller	Adjust the distance appropriately
	The label paper is not straightened, and the peeled label is not straight	Adjust the feeding tray device to tighten the label
6. Large displacement of the label at the beginning and the end after the roll is applied	The peeling plate is not parallel to the axis of the bottle to be labeled	Adjust the adjustable roller, the position of the stripping plate, so that the bottle holding roller, the stripping plate and the overlaid roller are parallel
	The label tape swings back and forth when the label tape is hung obliquely or pulled.	Fasten the stop ring on the guide roller to prevent the label from swinging back and forth
	The labeling area of the labeling area has too much error in diameter	The reason for being posted on the round bottle
	The distance between the peeling label and the bottle body is too far or there is a slight collision between the two	Normal state is about 3-5mm
	The mounting plate of the peeling label is not fastened, and it shakes during the labeling process	Retighten the screws
	The bottle is not clean or has water	Change a clean and dry bottle